

PERFORMANCE DATA SHEET NEMA PREMIUM NR CAN NEMA 12 - 12

Catalogue #: **MPOP-18**

HP	kW	Voltage	S.F. @ 60Hz	EFF.	P.F.	Frame	Design	L.R. Amps
3	2.24	575	1.15	88.5%	0.75	213T	B	26

60 Hz								
FLA							Code	F.L. RPM
208	230	416	460	480	575	600		
/	/	/	/	/	3.4	3.26	K	1180

50 Hz								
FLA			S.F. @ 50Hz	Efficiency	Power Factor	Code	F.L. RPM	
190	380	415						
/	/	/	/	/	/	/	/	

Wgt. Lbs	PH	Duty	Insul. Class	Amb.	Elevation	Temp. Rise° C
136	3	Cont.	F	40°C	1000M (3300 Ft)	< 80

% Efficiency		% Power Factor		Torque		Winding Resist. Ω	Safe Cold Start (Secs)
Full Load:	88.5%	Full Load:	0.75	Full Load Ft/Lbs	13.4		
3/4 Load:	88.0%	3/4 Load:	0.68	Locked Rotor %	180		
1/2 Load:	86.0%	1/2 Load:	0.55	Break Down %	280		

Rotor Inertia Wk2 Lb-Ft2	Max Load Inertia Wk2 Lb-Ft2	Shaft Material	Frame Material	DE Bracket Type	ODE Bracket Type	Enclosure	NEMA Rating	Lead Wire Size
0.71	66	Standard	Rolled Steel	Standard	Standard	ODP	IP23	14 AWG

Ball Bearings		Grease	Mount Type	Orientation	Paint	Sound Pressure @ 3FT	Sound Power
DE	ODE						
6208	6208	Sealed Bearings	Rigid	Horizontal	Green	61	71

Inverter Duty. Motor meets MG1 parts 31.4.4.2	Constant Torque Range	Variable Torque Range	Constant HP RPM
	10:1	20:1	1800

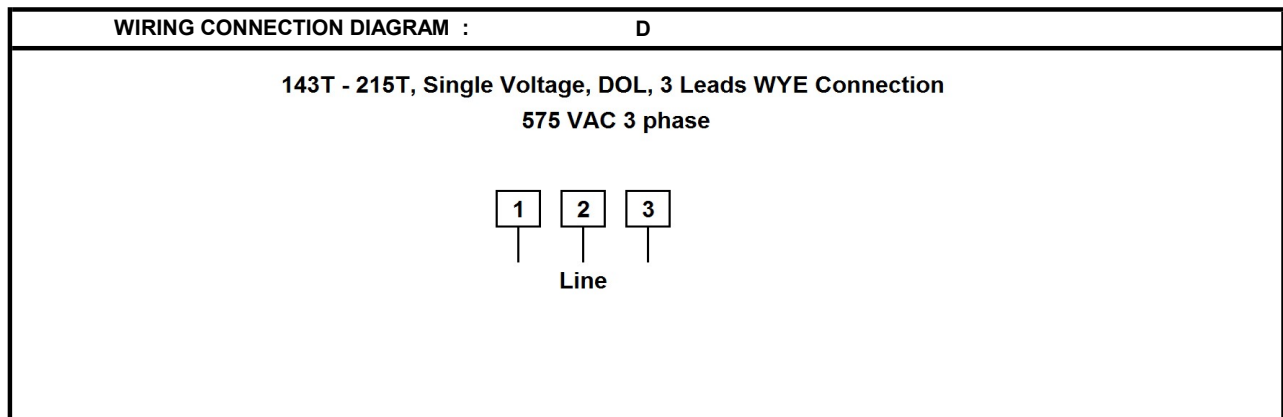

Date: 2020-02-17
 Customer: _____
 Contact: _____
 Submittee: J.C. Lavallée

Catalogue #: **MPOP-18**

NEMA PREMIUM NR CAN NEMA 12 - 12										
HP	VAC	RPM	Enclosure	Frame	Frequency	Design	Poles	LR Code Letter	Insulation Class	Temp. Rise °C
3	575	1180	ODP	213T	60	B	6	K	F	< 80
	0Hz	6Hz	15Hz	30Hz	45Hz	60Hz	75Hz	90Hz	105Hz	120Hz
Amps	3.4	3.4	3.4	3.4	3.4	3.4	3.4	3.4	3.4	3.4
RPM	0	118	295	590	885	1180	1475	1770	2065	2360
Torq ft.lb	10.68	13.35	13.35	13.35	13.35	13.35	10.68	8.90	7.63	6.68
Peak Tq ft.lb	16.02	32.05	32.05	32.05	32.05	32.05	25.64	21.36	18.31	16.02
HP	0	0.3	0.8	1.5	2.3	3.0	3.0	3.0	3.0	3.0
	Locked Rotor	Pull-Up	Breakdown	Rated Load	Idle	Duty	S. F.	Ambient	Elevation	dBA @ 1M
Speed (RPM)	0.0	504	960	1180	1200	Continuous	1.15	40°C	3300 ft	61
Current (Amps)	26.0	22.1	15.5	3.4	1.8	VFD Rating: Meets MG1 parts 31.4.4.2				
Torque (ft.-lbs)	24.0	18.0	37.4	13.4	0.0	C.T.	10:1	V.T.	20:1	

Motor Speed Data

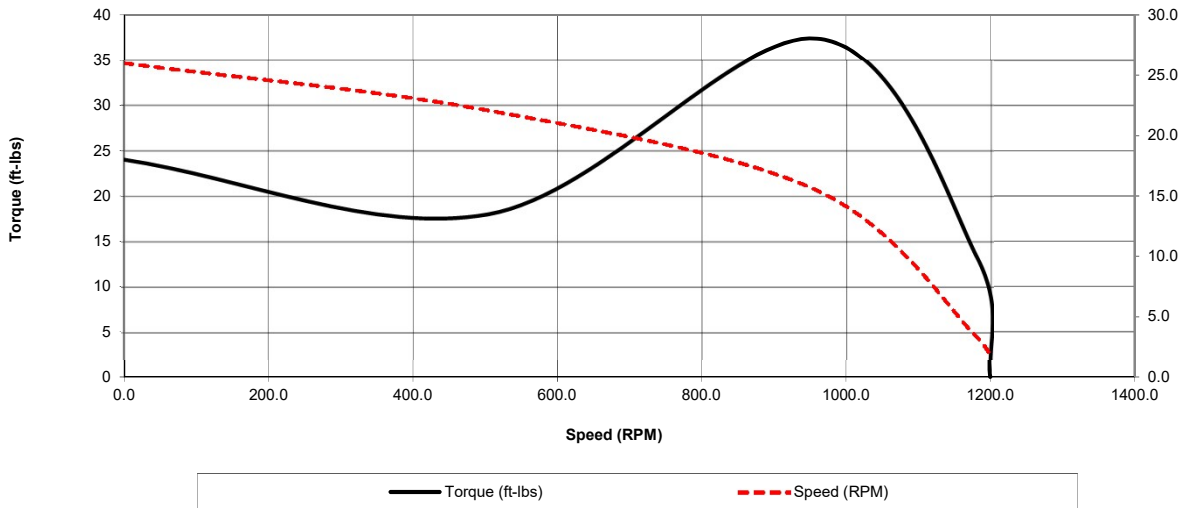

Motor Torque Capability vs RPM

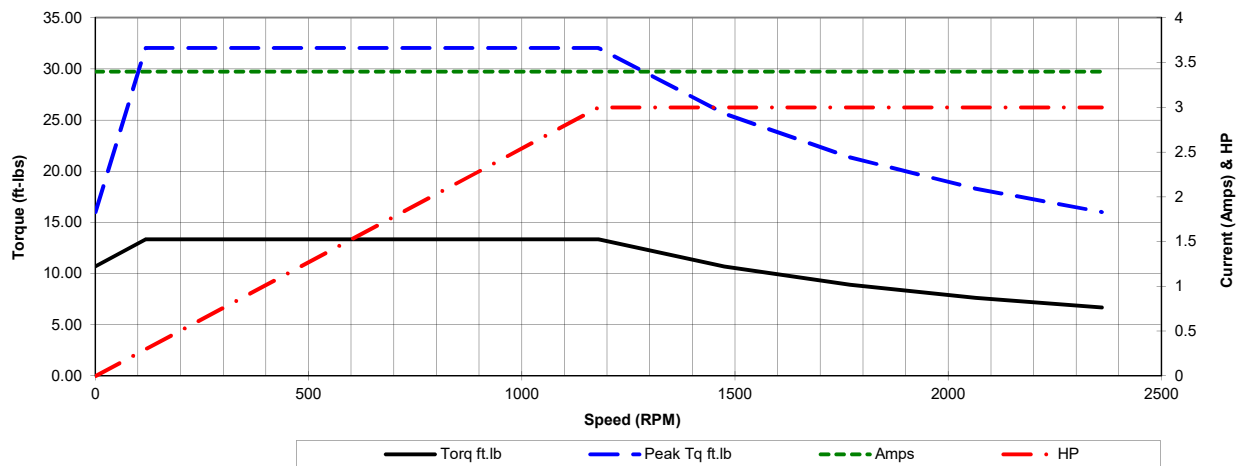



Date: 2020-02-17
 Customer: _____
 Contact: _____
 Submittee: J.C. Lavallée

Catalogue #: **MPOP-18**

NEMA PREMIUM NR CAN NEMA 12 - 12										
HP	VAC	RPM	Enclosure	Frame	Frequency	Design	Poles	LR Code Letter	Insulation Class	Temp. Rise °C
3	575	1180	ODP	213T	60	B	6	K	F	< 80
Load %	0%	25%	50%	75%	100%	125%	150%			
Amps	1.76	1.99	2.28	2.78	3.40	4.08	4.80			
Torq ft/lbs	0	3.30	6.62	9.97	13.35	16.76	20.20			
RPM	0	1195	1190	1185	1180	1175	1170			
Eff	0	83.50	86.00	88.00	88.50	88.50	88.50			
PF	0	33.8	55	68	75	77.7	79.4			
	Locked Rotor	Pull-Up	Breakdown	Rated Load	Idle	Duty	S. F.	Ambient	Elevation	dBA @ 1M
Speed (RPM)	0	504	960	1180	1200	Continuous	1.15	40°C	3300 ft	61
Current (Amps)	26	22.1	15.5	3.4	1.7612	VFD Rating: Meets MG1 parts 31.4.4.2				
Torque (ft-lbs)	24.03	18.03	37.39	13.35	0.0	C.T.	10:1	V.T.	20:1	

